

CASING CUTTING TEETH



Impossible ? I'm possible !

Contact Us

SAMHOON CO., LTD.

Head Office: 121, Hallim-ro, Hallim-myeon, Gimhae-si, Gyeongsangnam-do, Korea

Factory: 33, Myengdog-ro, Hallim-myeon, Gimhae-si, Gyeongsangnam-do, Korea

TEL : +82-55-343-1219

FAX : +82-55-345-1012

E-MAIL : samhoonjim@gmail.com / sam_hoon@nate.com

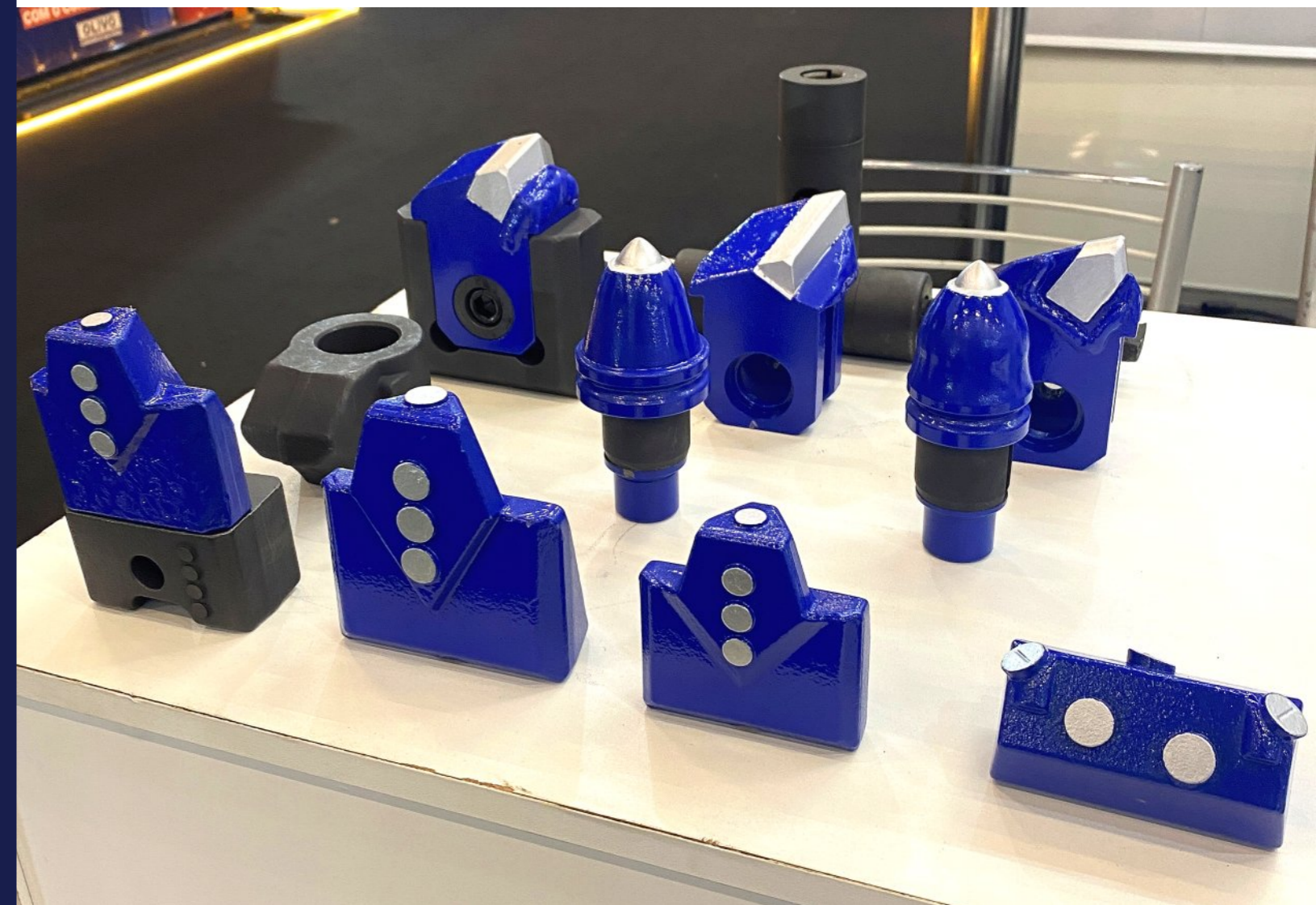

ROTARY DRILL RIG
TRENCH CUTTER

CASING OSCILLATOR
CASING ROTATOR

WELDING CASING TEETH

FOUNDATION DRILLING

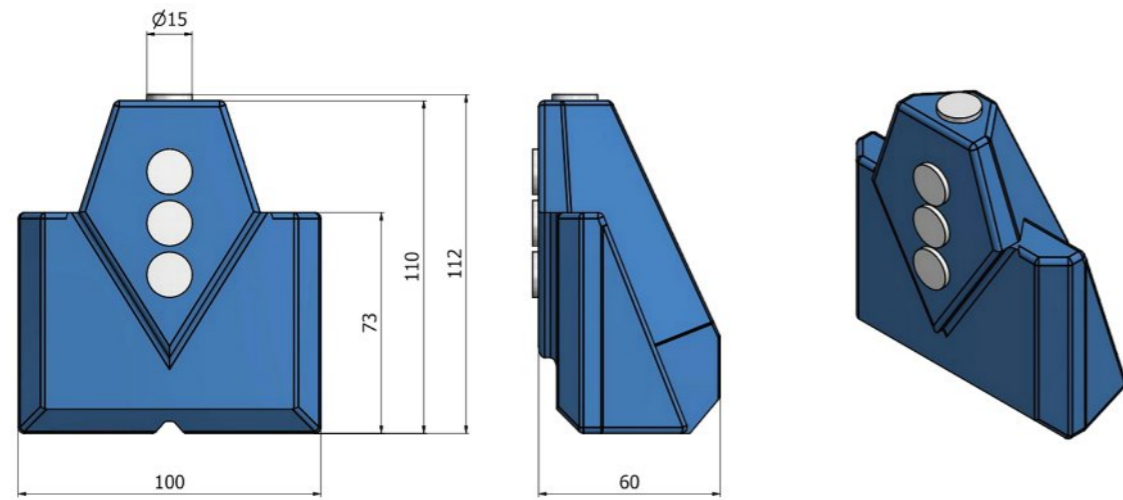

<SB-100>

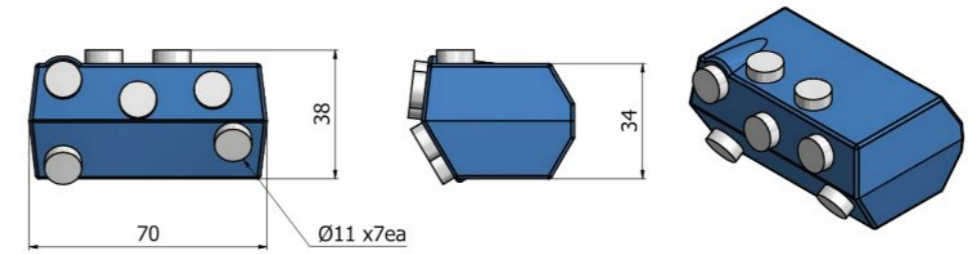

<SB300>

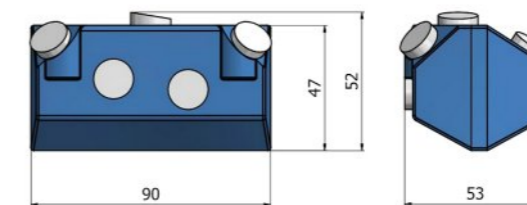
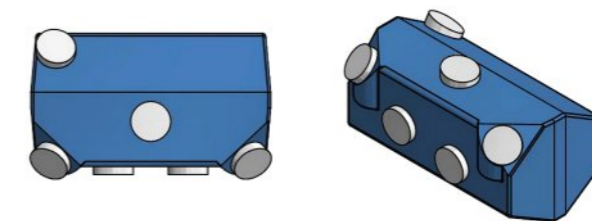

<SB400L>

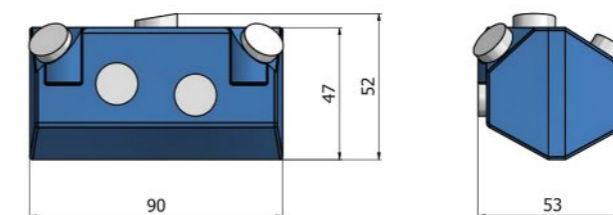
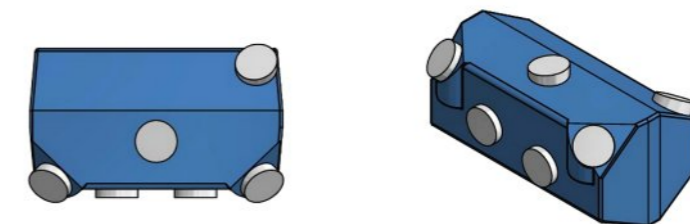

<SB400R>

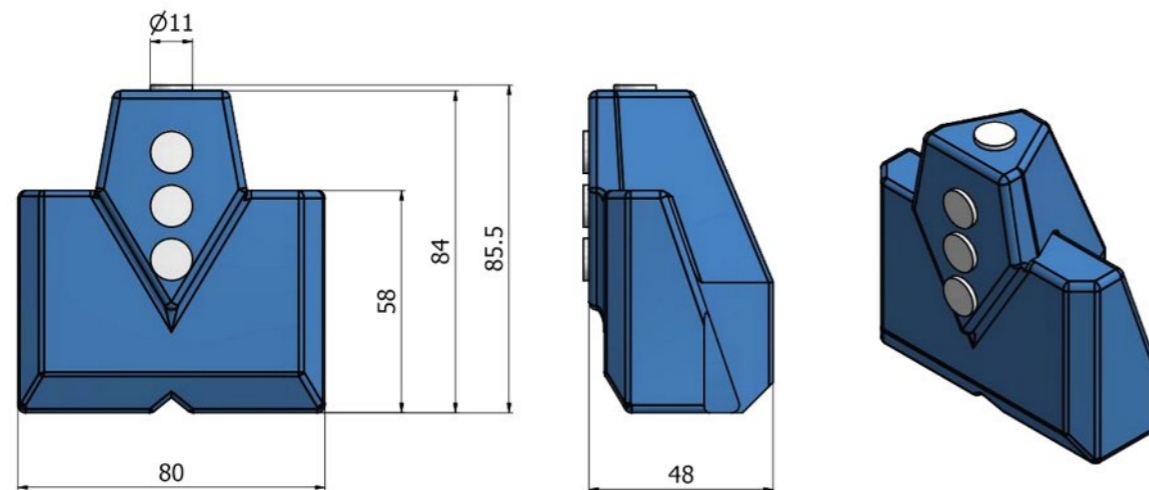

<SB-200>

WELDING CASING TEETH

FOUNDATION DRILLING

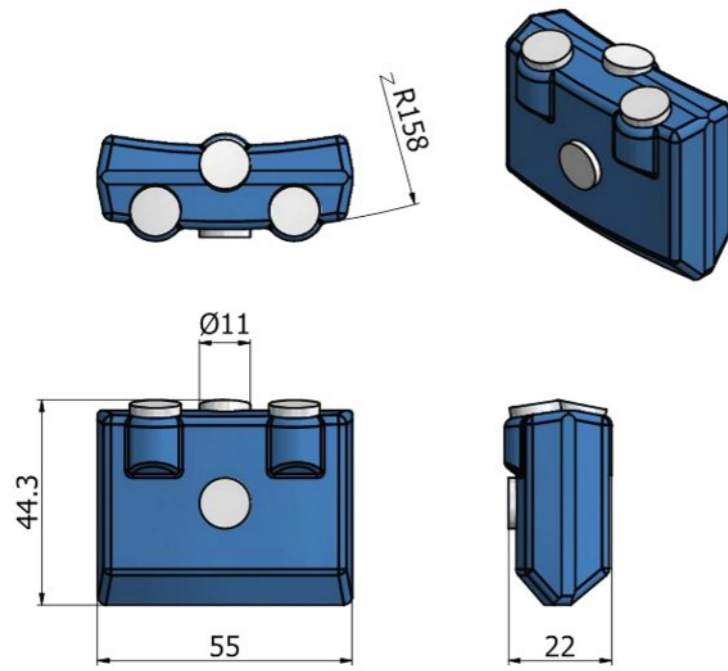

<SB-500>

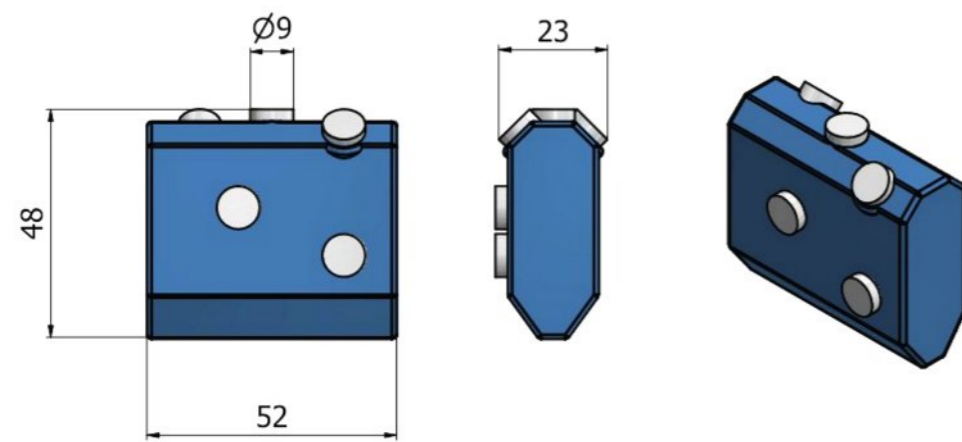

<SB-600>



QUICK CHANGE TEETH

FOUNDATION DRILLING

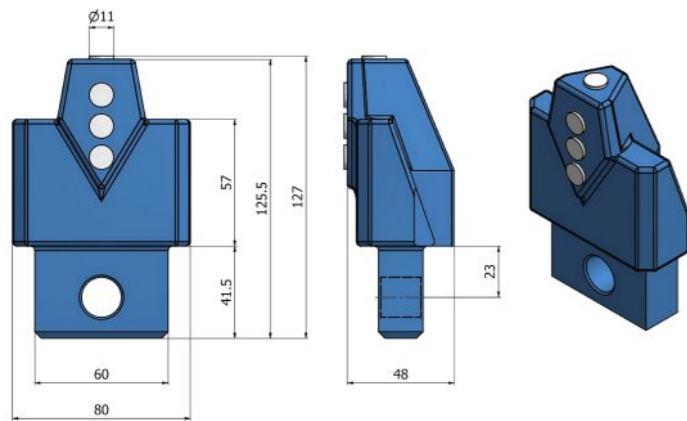

<SBH-100>

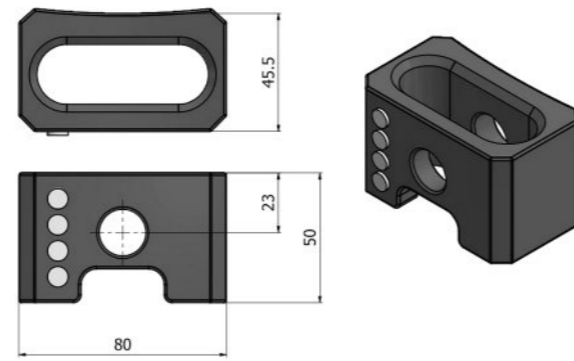

<SBH-101>

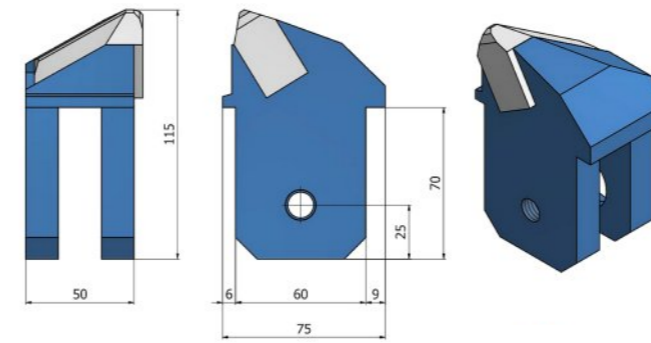

<SBR-100R>

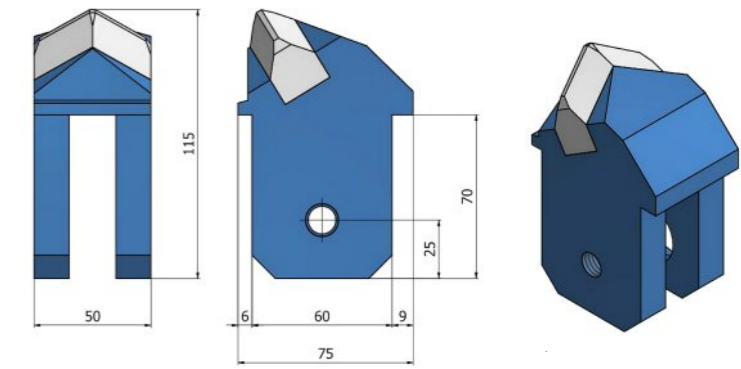

<SBR-100L>

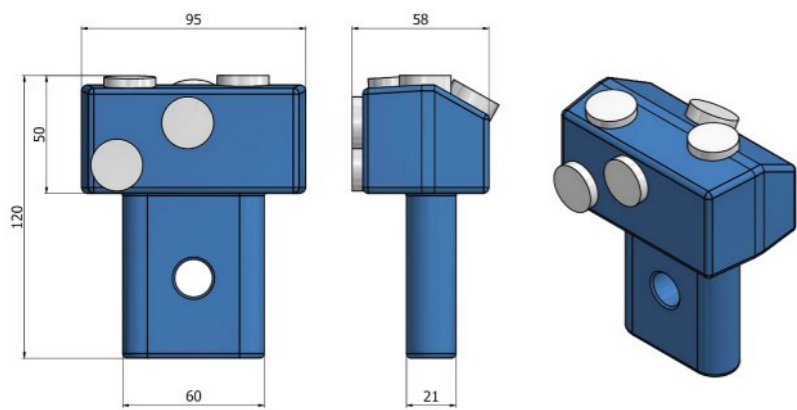

<SBH-200>

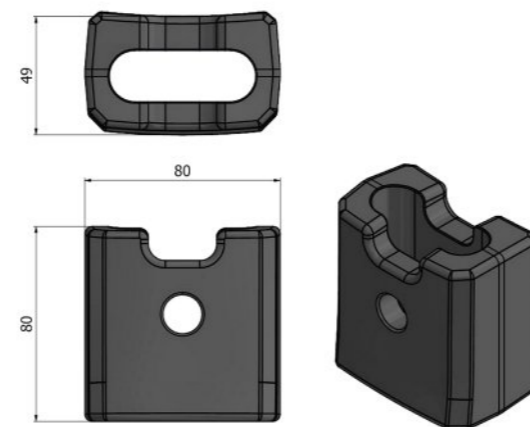

<SBH-201>

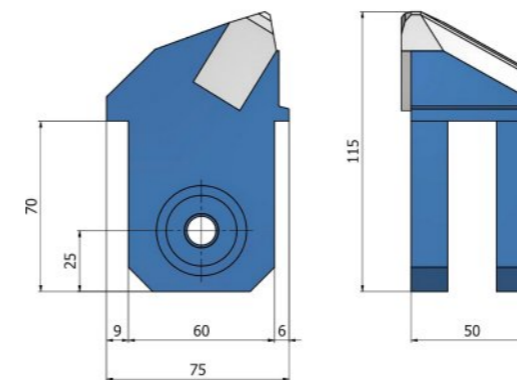

<SBR-100C>

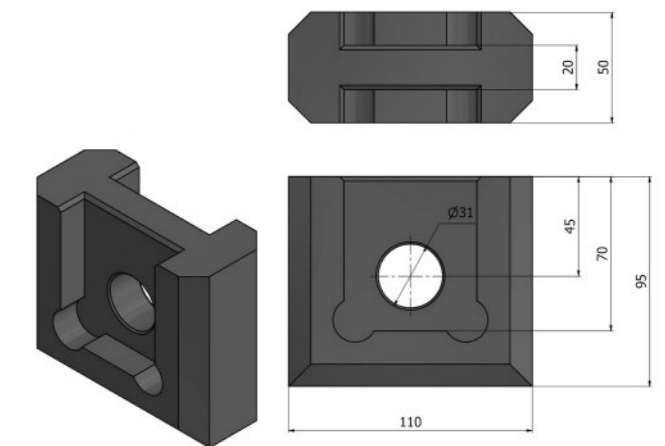

<SBR-100H>

QUICK CHANGE TEETH

FOUNDATION DRILLING

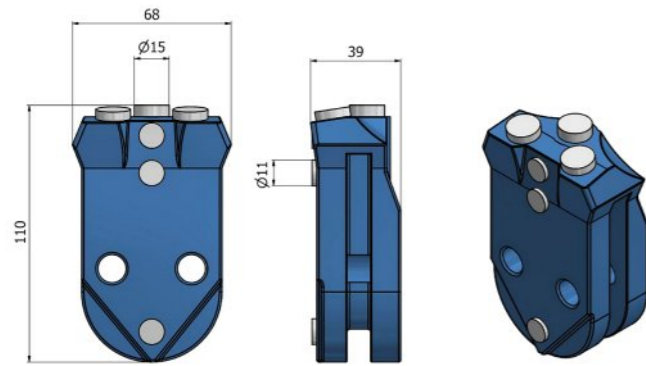

<SH-WS39>

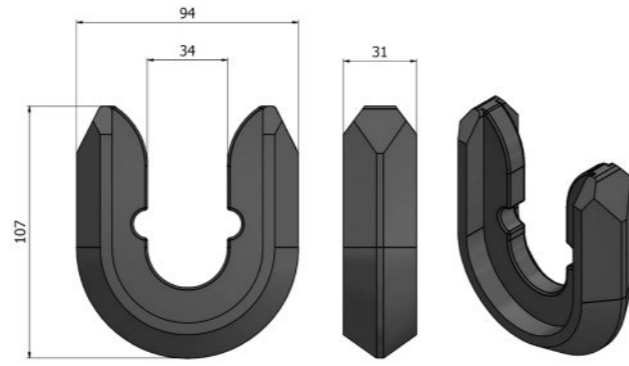

<SH-WSH39>

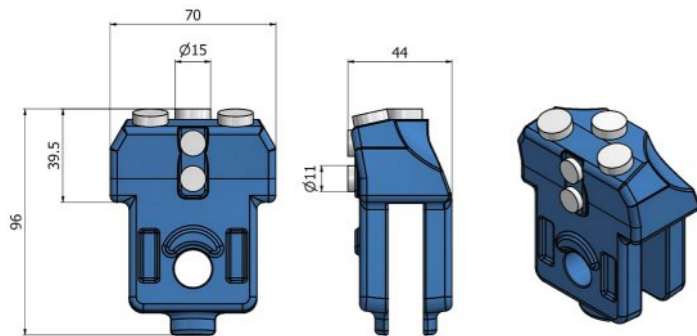

<SH-BA47>

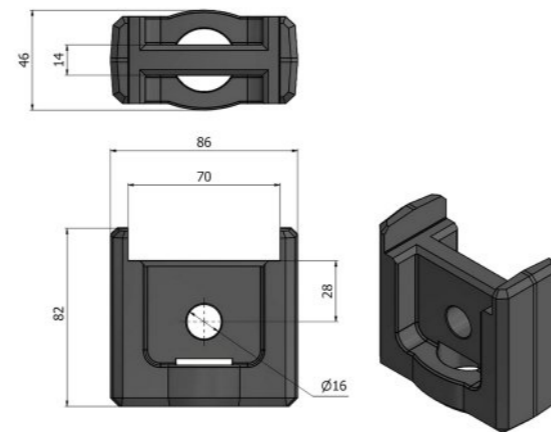

<SH-BAH47>

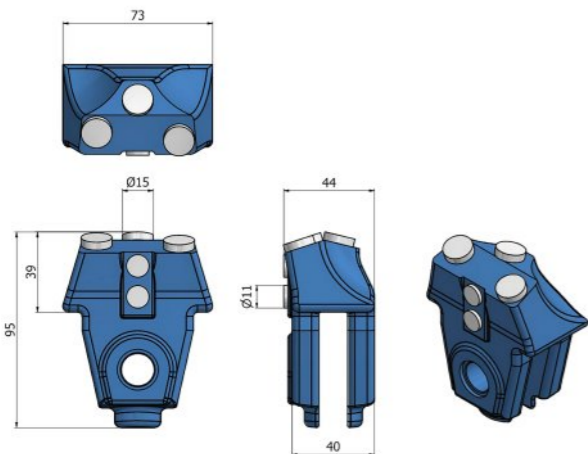

<SH-BA63>

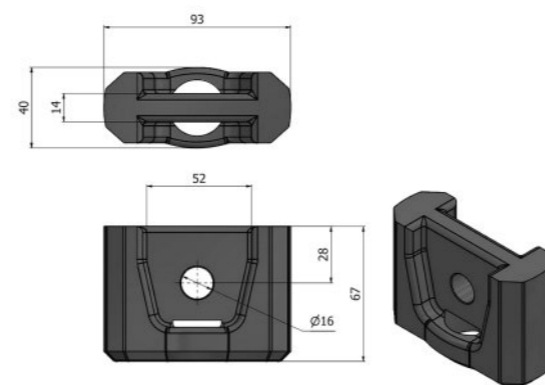

<SH-BAH63>

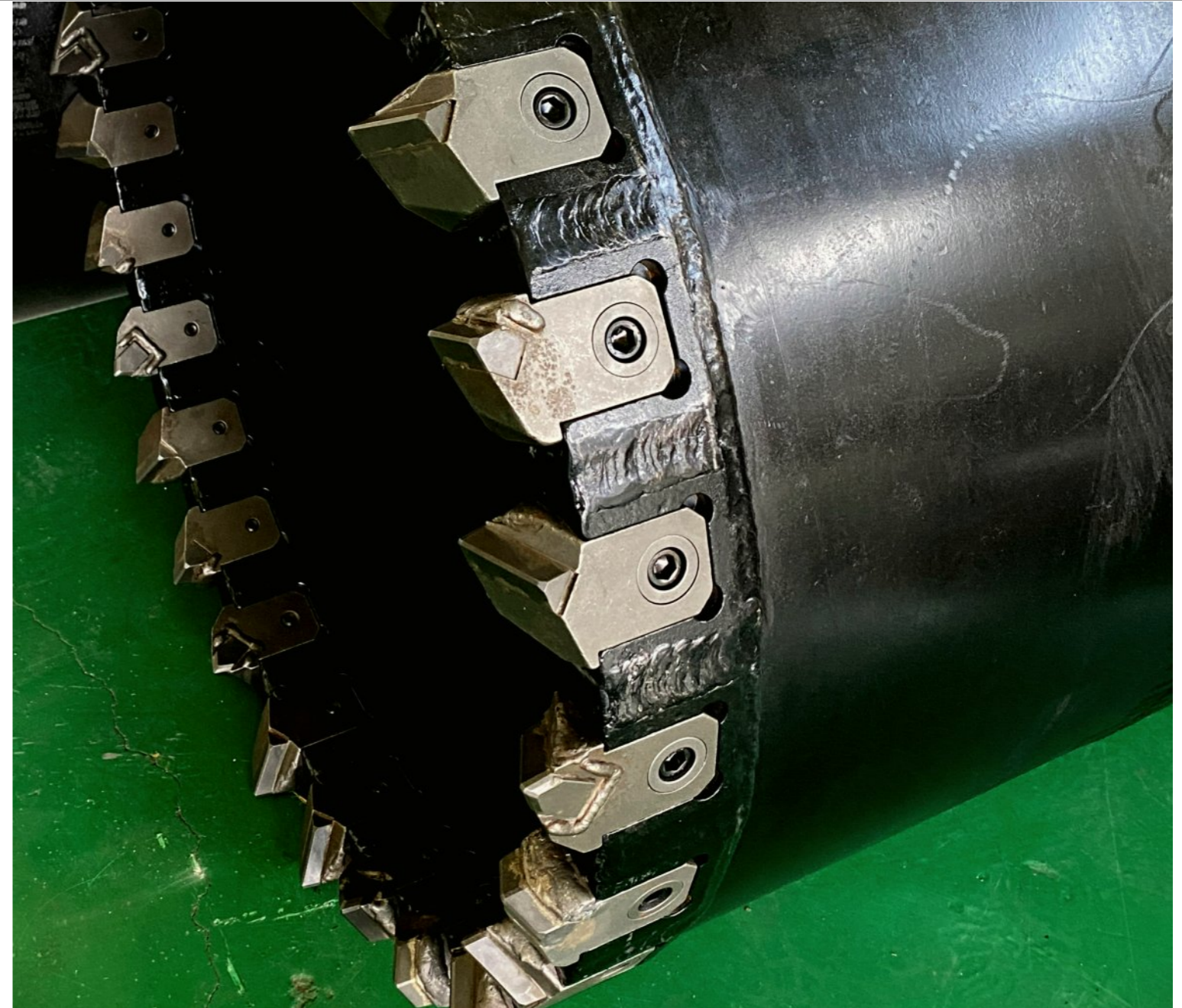

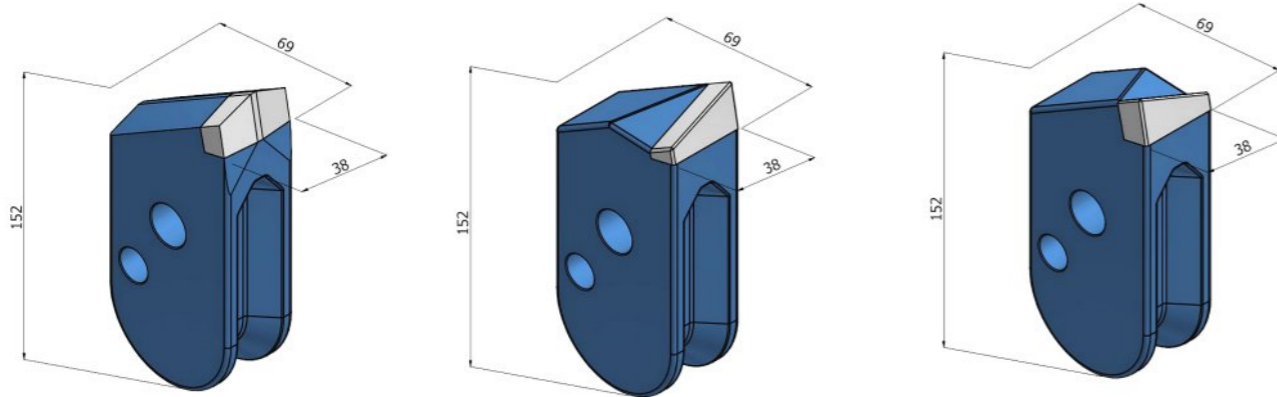

<SH-DW-001C>

<SH-DW-001R>

<SH-DW-001L>

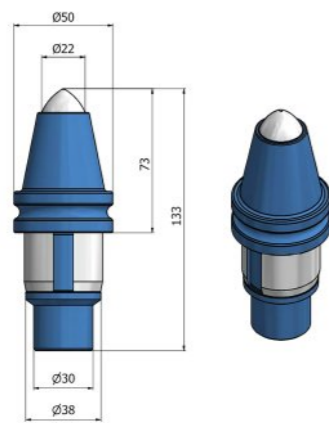

<SH-R50x22>

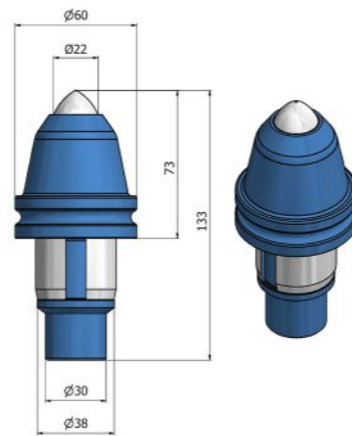

<SH-R60x22>

SAMHOON HIGH-TECH TOOLS



TUNGSTEN CARBIDE TIPS

- High-purity raw materials are used for high strength
- Managed pore-free tungsten carbide quality under internal control

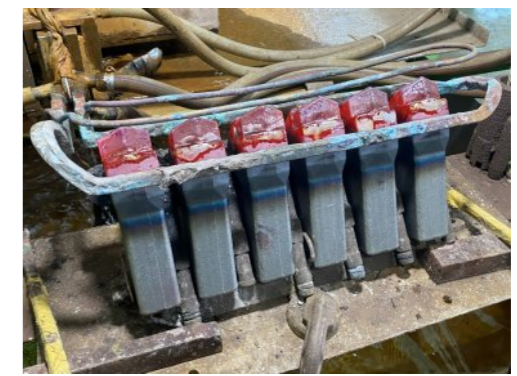

SOLDERING PRODUCTION

- Production facilities and processes specially developed to perfection by experts in the combination of tungsten carbide and steel



STOCK MANAGEMENT

- Keep suitable quantities of cutting teeth in stock
- Fast lead time for customer's project and satisfaction



QUALITY ASSURANCE

- Continuous quality testing of the entire manufacturing chain all the way up to the installation site